

## DECLARATION OF CONFORMITY

We, FHC, Inc., 1201 Main Street, Bowdoin, Maine 04287 telephone number 207-666-8190, fax number 207-666-8292, declare under sole responsibility that the product:

Model # Serial #

to which this declaration relates, is in conformity with the following standards:

EN292, Parts 1 & 2

Following the provision of the machinery (89/392/EEC) Directive:

The Technical Construction File is maintained at:

1201 Main Street  
Bowdoin, ME 04287

DATE OF ISSUE: \_\_\_\_\_

PLACE OF ISSUE: \_\_\_\_\_

1/16/2018

X 

---

Fred Haer  
President & CEO  
Signed by: Frederick Haer





*Providing Instrumentation and Apparatus for Cellular Research, Intraoperative Recording, and Microneurography; Micro-electrodes, Micropipettes, and Needles to the Neuroscience Community for 30 years.*

**50-12-1C  
50-12-2B**

**Hydraulic Probe Drive  
Chronic Adaptor**



**FHC Headquarters**  
1201 Main Street,  
Bowdoin, ME, 04287 USA  
Fax: 207-666-8292  
E-mail: [fhcinc@fh-co.com](mailto:fhcinc@fh-co.com)  
[www.fh-co.com](http://www.fh-co.com)

24 hour technical service  
+1-207-666-8190  
1-800-326-2905(US & Can)

**FHC Europe**  
(TERMOBIT PROD srl)  
129 Barbu Vacarescu Str,  
Sector 2  
Bucharest 020272  
Romania

L005-18C



# TABLE OF CONTENTS

## **1 Operational Manual**

- 1.1 Features
- 1.2 Description
- 1.3 Technical Summary

## **2 Reference Manual**

- 2.1.5 Warranty
- 2.1.6 Policies
- 2.1.7 Service
- 2.2.1 Installation of Master Cylinder in Drive Unit
- 2.2.3 Attachment to Chronic Adaptor
- 2.7 Maintenance
  - 2.7.1 Routine Maintenance
  - 2.7.2 Replacement of Damaged Diaphragm
  - 2.7.3 Filling the Hydraulic System
  - 2.7.4 Replacing Nylon Tubing



# 1 Operational Manual

## 1.1 Features

- Miniature Hydraulic Probe accepts metal and glass microelectrodes as well as amplifier probes
- Sealed system eliminates periodic refilling
- Versatile! Mounting arrangements available for acute and chronic preparations
- Drive Systems include manual and motorized control units

## 1.2 Description

The 50-12-1C Hydraulic Probe Drive features 15mm axial travel and includes provision for mounting metal or glass microelectrodes as well as our preamplifier probes. The probe is provided with a mounting rod for use on most stereotaxics and micromanipulators. It can be mounted on chronic systems using the 50-12-2B Chronic Adaptor. The probe drive is connected to the master cylinder by 8 feet of flexible tubing (other lengths can be specified), and is advanced with any of three FHC drive systems.

The Probe Drive includes a clamp arrangement suitable for holding most acute electrodes in one of several slots on the front of the probes moving platform.

The 50-12-2B Chronic Adaptor is used to convert the 50-12-1C Hydraulic Probe Drive for use with FHC, Inc. Chronic Microelectrode Systems or other systems where the electrode placement system supports the drive.

Our hydraulic probe is also easily mounted on any of FHC's guide tube drives. This will provide for a guide tube, greatly extend the electrodes range of axial travel (up to an additional 65mm with some guide tube drive models) and to provide for both a coarse and fine knob driven electrode advance.

The Chronic Adaptor includes an "L" shaped adaptor which fits chronic or acute systems and modifies the slave cylinder to accept an FHC electronic probe (preamplifier).

## 1.3 Technical Summary

### 1.3.1 Specifications

**Travel:** 15mm minimum

**Dimensions:** please refer to drawing 1064D1.00 and 50-12-1C/2B for dimensions.

NOTE: tubing connecting slave and master cylinder is 8 feet. Other lengths, up to 20 feet, may be specified.

## 2 Reference Manual

### 2.1.5 Warranty

All FHC products are unconditionally guaranteed against defects in workmanship for one year from date of shipment as long as they have been exposed to normal and proper use. Although the one year warranty may have expired, please contact our Service Department before attempting any repairs or alterations. Many of these repairs will still be performed at the factory at no charge to the customer.

### 2.1.6 Policies

1. **TECHNICAL SUPPORT:** It is our policy to provide our customers with the most comprehensive technical support in the industry. If any questions arise or problems occur, we encourage you to call or write and we promise to promptly and comprehensively respond to your requirements.
2. **TRADE-UP POLICY:** It is our policy to offer customers trade-up ability as new and/or expanded capabilities for their instruments are announced. In many cases, full credit will be given. In general, we will allow 100% credit for two years and depreciate 20% per year thereafter. Please contact our Marketing Department for information relating to your particular situation.

### 2.1.7 Service

Should service be required, please contact our Service Department for return instructions (207-666-8190). Carefully pack the instrument before returning. Save any packing retainers for future use.

Please include a note indicating:

1. The model number and purchase date of the instrument.
2. The person to contact if questions arise.
3. The "symptoms" indicating that repair is necessary.

If the instrument is not covered by the warranty, a quotation will be forwarded to the sender detailing the repairs necessary and charges, before repair is begun.

### 2.2.1 Installation of Master Cylinder in Drive Unit

The end of the Hydraulic Probe Drive master cylinder is 1/2" in diameter. It fits into a bored hole in the front of FHC drive units; a 1/4" diameter spindle which drives the probe drive piston extends from this hole.

Note that the master cylinder has a 1/8" groove near its end. Set screws in the drive unit seat in this groove and hold the master cylinder in position.

To install the hydraulic system, retract the drive unit to its minimum position (15.00 on the scale for manual units, maximum reverse direction for motor drive units).



Insert the master cylinder into the mounting hole of the drive unit. Push it in firmly until it "bottoms out". At this point, the micrometer spindle should have forced the slave cylinder platform out approximately .2mm. Holding the master cylinder in position, tighten the set screws on each side of the drive unit to secure the cylinder.

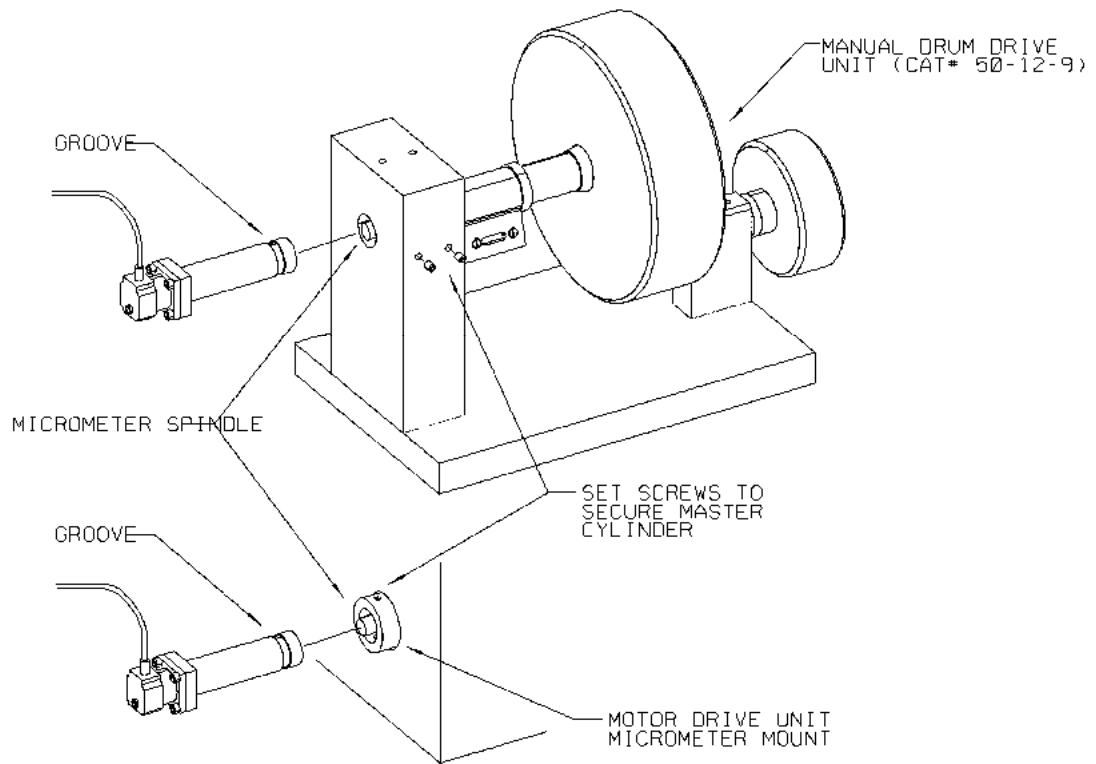

## 2.2.2 Installation of Chronic Adaptor

To install the Adaptor, remove the rod from the Probe Drive by removing the 2-56 x 1/8" cap screws on the back of the slave cylinder using the hex key provided. Also remove the electrode clamp on the Probe Drive by removing the spring from the Platform Retainer; replace the spring after the clamp is taken of.

Electrodes or guide tubes are clamped to the Probe Drive platform by using the plastic clamp plate and 2-56 x 1/4" cap screw provided with this assembly.

The 3/16" hole at the end of the "L" fits over the adaptor guide of the Semi-Chronic System. Tighten the screw at this hole to secure the assembly in place.

## 2.7 Maintenance

### 2.7.1 Routine Maintenance

In normal operation, the hydraulic system does not require periodic refilling. A rinse with distilled water, followed with an acetone or alcohol rinse is recommended to remove salts and accumulated dust. No lubrication is required or recommended.

### 2.7.2 Replacement of a Damaged Diaphragm

The Hydraulic Probe Drive System works on a rolling diaphragm principle. The diaphragm resembles a top hat, which can be forced inside out. There is one of these diaphragms in both the master and slave cylinders. Note that fluid is constrained between the two diaphragms. This yields a much more reliable system since it minimizes the chances for leaks to occur.

Observe that the diaphragm (FHC Part # V2-26) has one smooth side and one textured side (fabric reinforced).

NOTE: the smooth side always faces the fluid. If the diaphragm is put in backwards, the pressure will force the "rubber-like" layer away from the fabric. Diaphragms are provided with the textured side on the outside of the top hat. If you are re-using a diaphragm, be certain that you start with the correct configuration.

#### a. Replacing the Master Cylinder Diaphragm

1. Remove the four cap screws holding the chamber to the master barrel.
2. Use a 1/4" rod to push the piston inside the master cylinder to the filled extended position. With the diaphragm in such a configuration that the textured side is on the outside of the top hat, use the rounded end of the piston to push the top of the hat through the brim until the inside of the top is about even with the brim. Check to be sure that the diaphragm is uniformly folded around the piston. Then, push the piston with the diaphragm into the master barrel so that the brim of the diaphragm lays in the cut out of the barrel. Note again that the smooth side of the diaphragm should now be facing out from the barrel.
3. The chambers on each end of the nylon connecting tubing are identical and either one may now be carefully positioned over the barrel being certain not to disturb or wrinkle the diaphragm. Hold the chamber and barrel together and insert four 2-56 x 1/4" cap screws and tighten into position. Tighten the screws going around screw to screw gradually increasing the tension. The screws should be very secure when complete.

#### b. Replacing the Slave cylinder Diaphragm

1. Remove the four cap screws holding the chamber to the Slave Barrel.
2. Again, as in 2.7.1a above, pop the top of the diaphragm up even with the brim this time using the plunger of the platform assembly. Remove the plunger when the diaphragm has been uniformly folded around it. Be careful not to unfold the diaphragm.
3. Now insert the plunger into the slave barrel so that it protrudes above the barrel. Reposition the diaphragm on the top of the plunger. Pulling the plunger back; seat the diaphragm on the cut out portion of the slave barrel.

4. Place the chamber into position and, holding it carefully, being certain not to disturb the diaphragm, tighten the 2-56 x 1/4" cap screws in 2.7.2a.3.

### **2.7.3 Filling the Hydraulic System**

Automotive automatic transmission fluid is used to fill the tubing and chambers. We have found that this fluid gives less maintenance problems than other fluids such as distilled water. Fluid is introduced through the inlet ports on the top of each chamber. Valves for these inlet ports consist of 2-56 x 1/8" capscrews (FHC part #Z6-17) with an O-ring seat (FHC part #Z2-25).

1. Remove the valves from the chambers on the slave and master cylinders. Put the slave cylinder in a small empty jar and set it on a shelf about 12" above the master cylinder level.
2. Two 2 1/2 cc syringes are required for filling. Fill one syringe with fluid and push it firmly into the inlet port of the master cylinder so that a seal is created.
3. Push down the syringe plunger transferring the fluid into the master cylinder and tubing.
4. Add fluid in this way until it is just ready to enter the slave cylinder. Then, refill a syringe so that a full 2 1/2 cc is ready for injecting.
5. Continue to add fluid through the master cylinder. As fluid begins to enter the slave cylinder, tap the slave cylinder to be sure air is excluded. When fluid has drained through the port on the slave cylinder and no air bubbles are noted, insert a valve into the slave cylinder port and tighten into position.
6. Carefully inject more fluid until the plunger on the slave cylinder has been extended about 1cm. Then, quickly insert a valve into the master cylinder port and tighten into position.
7. Replace the springs securing the platform to the slave cylinder. When the springs are in place, the platform should still be extended at least .5cm from the slave cylinder.
8. Using a rod with a diameter less than 3/16", push in the piston on the master cylinder causing the slave cylinder and platform to move forward. Do this several times and note that no air bubbles are present. If bubbles are noted, it will be necessary to remove the valve from both cylinders and repeat the procedure as in 3-5 above.
9. If no bubbles are noted, carefully loosen the valve on the master cylinder port so that a very small amount of fluid is exuded by the pressure of the springs on the slave cylinder. Allow the platform on the slave cylinder to withdraw until it is approximately 1mm from the slave cylinder. Then tighten the valve securely.
10. If any oil has been spilled over the assemblies, rinse the tubing and cylinders in ethyl alcohol or acetone to remove it.

### **2.7.4 Replacing the Nylon Tubing**

The fittings used on the Hydraulic Probe drive require a number of special tools to provide a positive seal. For this reason, we do not recommend loosening the fittings for any reason except to replace the tubing.

In the event that the tubing does become kinked or damaged, or the fittings start to leak, FHC can provide a hydraulic tubing repair kit, catalog # 50-12-10 which will include detailed instructions, a replacement length of tubing with pre-assembled fittings, and a specially designed torque wrench. Alternatively, you may simply return your Hydraulic Probe to us for Repair and Re-filling.