

QUALITY INSPECTION SUMMARY

- 50-12-8 Manual Drive Unit
- 50-12-8-02 Electronic Manual Drive Unit
- 50-12-9 Manual Drum Drive Unit
- 50-12-9-02 Electronic Manual Drum Drive Unit

We have made every effort to manufacture this instrument to the highest quality standards. All assemblies have been thoroughly tested and inspected at the factory as follows:

Initial Assembly Inspection	_____	<input type="checkbox"/>
Initial QC Inspection/Calibration	_____	<input type="checkbox"/>
Final Performance Inspection	_____	<input type="checkbox"/>

Packaging Inspection Initials: _____ Date: _____

Items included with this catalog number are labeled and packaged separately in shipping carton.

Description	Quantity	Checked
Catalog Item (as marked above)	_____	<input type="checkbox"/>
A901-03 Instruction Manual	_____	<input type="checkbox"/>
Drum Drive Accessories (Hex key and extra set screw)	_____	<input type="checkbox"/>

DECLARATION OF CONFORMITY

We, FHC, Inc., 1201 Main Street, Bowdoin, Maine 04287 telephone number 207-666-8190, fax number 207-666-8292, declare under sole responsibility that the product:

Model # _____ Serial # _____

to which this declaration relates, is in conformity with the following standard:

EN292, Parts 1 & 2

Following the provision of the machinery (89/392/EEC) Directive.

The Technical Construction File is maintained at:

1201 Main Street
Bowdoin, ME 04287

DATE OF ISSUE: _____

PLACE OF ISSUE: Bowdoin, Maine USA

SIGNED: _____
Frederick Haer

Instruction Manual
50-12-8 Manual Drive Unit
50-12-8-02 Electronic Manual Drive Unit
50-12-9 Manual Drum Drive Unit
50-12-9-02 Electronic Manual Drum Drive Unit

Manual Drive Units

Table of Contents

- 1 Operation Manual
 - 1.1 Features
 - 1.2 Description
 - 1.3 Technical Summary
 - 1.3.1 Specifications
 - 1.3.2 Controls / Connectors

- 2 Reference Manual
 - 2.1 Reference Information
 - 2.1.1 Packaging
 - 2.1.2 Mounting
 - 2.1.3 Inspection
 - 2.1.5 Warranty
 - 2.1.6 Policies
 - 2.1.7 Service

 - 2.2 Installation
 - 2.2.1 General Information

- 3 Technical Manual
 - 3.0 General Documentation Information
 - 3.1 Specific Packaging Description

1 Operation Manual

1.1 Features

A compact manual drive system with:

- Choice of dial, window, or digital display
- Choice of Drum or Thumbscrew adjustment
- Drum models include a cam-engaged fine feed knob
- Micrometer increments at 10 microns
- Easily accurate to 2 micron readout (with interpolation)
- Knurled surfaces for extra grip
- Stable base
- Heavy-duty machined parts for long wear

1.2 Description

The FHC Manual Drive Units have been designed to provide a smooth linear motion to drive our 50-12-1 series Hydraulic Probe Drives.

The 50-12-8 Manual Drive Unit includes a metric micrometer; each full clockwise rotation advances the piston 500 microns.

The 50-12-8-02 Electronic Manual Drive Unit includes a metric micrometer with a digital display; each full clockwise rotation advances the piston 500 microns.

The 50-12-9 Manual Drum Drive Unit includes a metric micrometer driven by a large drum, the rotation of which causes rapid probe movement and a fine feed drive that may be engaged by positioning the cam lever in the down position.

The 50-12-9-02 Electronic Manual Drum Drive Unit includes a metric micrometer with a digital display driven by a large drum, the rotation of which causes rapid probe movement and a fine feed drive that may be engaged by positioning the cam lever in the down position.

Each full turn of the drum is 500 microns. The micrometer dials read in 10 micron increments and can be read to + 2 microns by interpolation. The slave cylinder begins to move outward at 15mm on the dial and continues to 0mm.

NOTE: It is always advisable to retract the Probe Drive to its minimum position, i.e., the dial set to 15mm, when the system is not in use.

All Drive Units include a stable base with rubber feet that provides a slip and tip-resistant work area. The models without drum occupy only a 6" x 4" x 4" area. The models with drum occupy a 6" x 7.5" x 4" area.

1.3 Technical Summary
1.3.1 Specifications

Dimensions:

50-12-8,50-12-8-02 Units: 4"h x 4"w x 8"d (10 x 10 x 20cm). 3 lbs. (1.5kg)

50-12-9,50-12-9-02 Units: 5.5"h x 4"w x 8"d (14 x 10 x 20cm). 3.25 lbs. (1.75kg)

1.3.2 Controls / Connectors

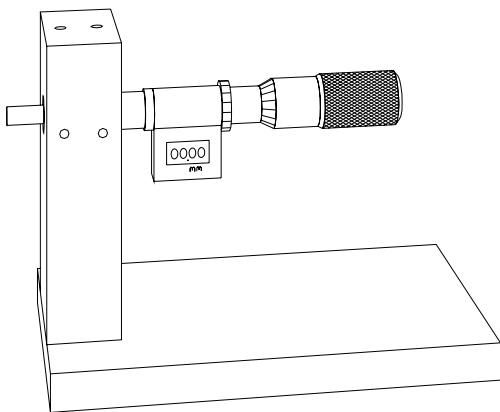

Model 50-12-8
Manual Drive Unit
(Model 50-12-8-02, not shown,
comes with Electronic Digital Display)

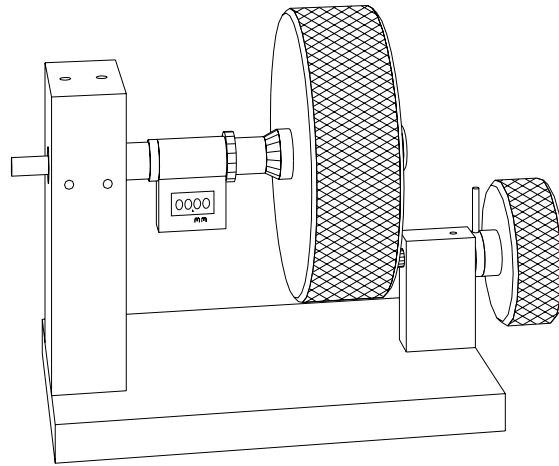

Model 50-12-9
Manual Drum Drive Unit
(Model 50-12-9-02, not shown,
comes with Electronic Digital Display)

2 Reference Manual

2.1 Reference Information

2.1.3 Inspection

FHC modules are factory checked and calibrated but should be carefully inspected before activating power.

If any exterior damage to the shipping carton is noted, the instrument should be inspected for obvious physical damage.

2.1.4 Power Connections

The Electronic models, 50-12-8-02, and 50-12-9-02 require battery power. These models are shipped with a battery in place, ready to use.

In the event the battery weakens, the display will show a dim reading. Replace with a new battery, No. CR2450. Removing the cover on the back of the micrometer allows access to the battery compartment. Install battery with the "+" side down, as noted on cover.

2.1.5 Warranty

All FHC products are unconditionally guaranteed against defects in workmanship for one year from date of shipment as long as they have been exposed to normal and proper use. Even though the one year warranty may have expired, please contact our Service Department before attempting any repairs or alterations. Many of these repairs will still be performed at the factory at no charge to the customer.

2.1.6 Policies

1. TECHNICAL SUPPORT: It is our policy to provide our customers with the most comprehensive technical support in the industry. If any questions arise or problems occur, we encourage you to call or write and we promise to promptly and comprehensively respond to your requirements.
2. TRADE-UP POLICY: It is our policy to offer customers trade-up ability as new and/or expanded capabilities for their instruments are announced. In many cases, full credit will be given. In general, we will allow 100% credit for two years and depreciate 20% per year thereafter. Please contact our Marketing Department for information relating to your particular situation.

2.1.7 Service

Should service be required, please contact our Service Department for return instructions (207-666-8190). Carefully pack the instrument before returning. Save any packing retainers for future use.

Please include a note indicating:

1. The model number and purchase date of the instrument.
2. The person to contact if questions arise.
3. The "symptoms" indicating that repair is necessary.
4. A note indicating proper sterilization of the instrument.

In order to safeguard our Repair Department personnel, we request that all returned equipment is sterilized by a method acceptable to the particular instrument, and that a note be included with the return indicating such.

If the instrument is not covered by the warranty, a quotation will be forwarded to the sender detailing the repairs necessary and charges, before repair is begun.

2.2 Installation

2.2.1 General Information

The FHC Manual Drive Units are shipped fully assembled and ready for attachment to a Hydraulic Drive system.

To install the Hydraulic Probe Drive, use the coarse drive to position the micrometer at the 15mm position. Insert the master cylinder end of the probe drive into the 1/2" hole in the drive unit. Be certain that the master cylinder is in as far as it can go and tighten the setscrew through the side hole using the hex key provided.

2.2.2 Instructions specific to the Electronic models:

Automatic OFF: The micrometer will turn off (the display will go blank) after 30 minutes of no spindle activity. Any movement of the spindle will activate the display with no loss of position reading.

HOLD Button: One button push will freeze the display and the word 'HOLD' will appear. A second push will update the display to the current position reading.

SHIFT/SET Button: One push of the button will change the function of this button to SET: it will change the function of the ZERO/ABS button to PRESET, and will change the function of the IN/mm button to LIMITS. See below for an explanation of the various functions.

ZERO/ABS Button: Depressing for less than one second will zero the display at any point (incremental mode). Depressing for longer than one second will return the display to the original reading (absolute mode), and the letters 'ABS' will appear.

PRESET Button: Allows for the input of any number into the display (for offset use).
To input values:

1. Place the spindle in the desired position.
2. Depress SHIFT/SET for secondary button functions. A small 's' will appear.
3. Press PRESET. The display flashes 'P', and the previous preset number (if any).
4. Press SET to index to a '+' or '-' sign.
5. Press PRESET to change from '+' to '-'.
6. Press SET to index to the first digit position, press PRESET to change the number.
7. Press SET and PRESET to index, and change remaining numbers.
8. Press SET to check for correct value. Press PRESET to accept ('P' will stop flashing).

IN/mm Button: Changes the display to either inch or millimeter reading.

Output: The micrometer is capable of data transmission through the output port to allow for analysis, data collection, and/or hard copy documentation. An interface cable is needed as well as an available RS232 port. Please contact FHC or Starrett Manufacturing for additional information.

Error message: The word 'Err 04' will display if the spindle is moved too fast. If this occurs, press the ZERO/ABS button.

Test Mode: If an unusual reading appears on the display, press the ZERO/ABS button until all segments are on. Then press any other button to return to normal mode.

3 Technical Manual

3.0 General Documentation Information

It is our policy to provide comprehensive product documentation with our instruments. Section 3 of our instruction information includes not only technical descriptions and calibration procedures but parts lists, schematics and parts layouts. We also maintain a service record file on each product, information of which is available to any instrument owner if in the future he should experience problems.

Section 3.4 includes our master parts list which details the assemblies for the instrument.

Parts layouts are provided for all relevant assemblies. These layouts include component values and circuit numbers unique to the assembly. In those cases where the density of the assembly is too high a separate drawing with circuit numbers is included.

Complete schematics are also provided for each instrument. Schematics include all components of an instrument and as such, one schematic may include two or more assemblies, e.g. front panel and captive circuit board assemblies. Whenever possible assemblies are separated or designated on schematics. Schematics, in addition to listing component values include circuit numbers. Because circuit numbers are unique to each assembly, the same circuit number e.g. C10 may be used twice on a schematic referring in one place to a 10 pF capacitor on a front panel switch and in another to a .47mF PCB mounted capacitor. However, functional considerations should remove any ambiguity.

Schematics are referenced by the instrument catalog number followed by a code which lists the total number of pages which constitute the complete instrument schematic i.e. 1/2, 2/2.

Assemblies are referenced by the assembly number followed by the number of pages code. In those situations in which a printed circuit board is wired to another assembly, for example a front panel, the identifying interconnections, wire colors, etc. are included with the front panel assembly.

3.1 Specific Packaging Description

To open an FHC, Inc. module for service or inspection, set the instrument upright, remove the front and rear screws holding the top right rail as viewed from the front, and lift the rail upwards. This releases the top and side panels exposing the circuit boards and front and rear panel connections.

NOTE! Many modules, which contain their own power supplies, have circuit boards mounted on both side panels. As a result, it is important to use caution when moving the right panel to avoid damaging wiring.

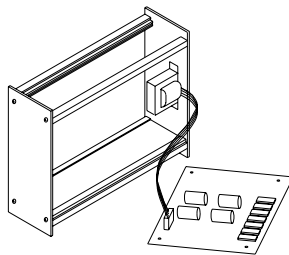

Fig 2.1.1a Fig 2.1.1b