

ECM Experimental Control Module

Product Features & Description

INSTRUMENTATION AND MICROELECTRODES FOR NEUROSCIENCE

The ECM (Experiment Control Module) is a user-programmable device that is designed for real-time control of various instruments in an experimental setup. The ECM is designed to overcome any difficulties with integrating the various pieces of equipment in a single experimental setup, and synchronizing them with sub-millisecond accuracy. Rather than just a time sequencer that outputs logical time signals at predefined time intervals, the ECM continuously monitors experimental variables and adapts its state according to the user defined algorithm. In simple psychophysics/ behavioral experiments, the ECM is used to enable acquisition of advanced behavioral variables, monitoring subject's responses, and synchronized stimulus presentation. The ECM together with FHC's complete line of microelectrodes, MCM Microelectrode Positioning Systems, APC Neural Spike Recording Systems and a variety of readily available visual/auditory/electrical stimulus generators, behavioral variable monitors, and reward systems constitute a completely integrated electrophysiology experiment setup.

The ECM enables a researcher to perform real time specialized digital data acquisition through the implementation of a finite state machine. For example, an experimental variable such as an eye/arm position can be used as a real time trigger of other instruments in the experimental setup (i.e. data acquisition), which in turn trigger other instruments, such as, reward.

All processing tasks for the ECM are performed by an on-board 32 bit floating-point digital signal processor (DSP). All functions are implemented in the hardware and DSP firmware of the module. The 32 bit DSP allows real-time processing of input signals to control the devices in the setup with no data processing performed on the host PC. This enables non-real time computer operating systems (e.g. Windows) to run real time experiments. The role of the host PC is to enable the programming of the ECM, check its status, and retrieve acquired data for later summary. The communication between ECM and the host PC is via a standard USB interface.

The ECM software is designed as an ActiveX control that is inserted in an existing application (e.g. Matlab). There is no new programming language or graphic user interface to learn. The other hardware devices used in experimental setups (for instance visual stimulators) come with their own API/libraries Programming a certain experiment usually requires writing some code. Instead of having two independent applications that have to be

Features

- Centralized real time coordination of all experimental data (electrophysiological recording, behavioral, stimuli, reward)
- Triggered presentation of stimuli or reward based on behavioral data input.
- Considerably shortens the setup time of an experiment by integrating into standard widely used applications (ex. Visual Basic, Matlab, etc) supporting ActiveX.
- Real time processing of data by an advanced 32 bit floating point digital signal processor (DSP).
- Upgradeable firmware through the user-programmable 1.5MB FLASH memory.
- Growing downloadable library of user-contributed algorithms and applications available at www.neurocraft.com.
- Available as a stand-alone module or as a channel of the FHC APC Neural Spike Recording System.



With the ECM, researchers can easily correlate, in real time, data from multiple experiment variables.

ECM Experimental Control Module

Product Description (cont.) & Specifications

INSTRUMENTATION AND MICROELECTRODES FOR NEUROSCIENCE RESEARCH

synchronized and talk to each other, one can take advantage of the COM (Component Object Model) which allows inserting the ECM ActiveX control in the original application. A number of Matlab and Visual Basic samples are provided for using the ActiveX control.

The ECM is a software-upgradeable device. Its firmware is stored in a FLASH memory that can be re-programmed with the latest code version, available on our support site www.neurocraft.com. A web-based users group is also established on the site for a free exchange of software, under an open-source policy.

Specifications

Analog Inputs: 2 - 3.5mm mono jacks; alternately available as 2 pins on the front panel DB15 connector.

Digital Inputs: 4 TTL pins on the front panel DB15 connector.

Digital Outputs: 7 TTL pins on the front panel DB15 connector. 2 alternately available as 3.5mm mono jacks on the front panel. (Trial Trigger and Stim Trigger)

Analog Input Impedance: 20 kOhm

Analog Input Dynamic Range: -0.5V to +0.5V, or -10V to +10V; jumper selectable

A/D Sampling Resolution: 16 bits

Frequency Response: DC to 20 kHz

Memory: 1.5MB zero wait state fast SRAM data buffers, 256kB FLASH

Display: XY plot of the current value of the analog inputs

Computer Interface: Full Speed USB 1.1 (12Mbps)

Dimensions: 2.05" (5cm) width X 5.22" (13cm) height X 9.6" (24cm) depth

Weight: 1.30 lbs (.59 Kg)

Power Requirements:

Power Supply: 115/230VAC, 50-60Hz, 9W max. Country specific line cord.

ECM: 12V, 350mA

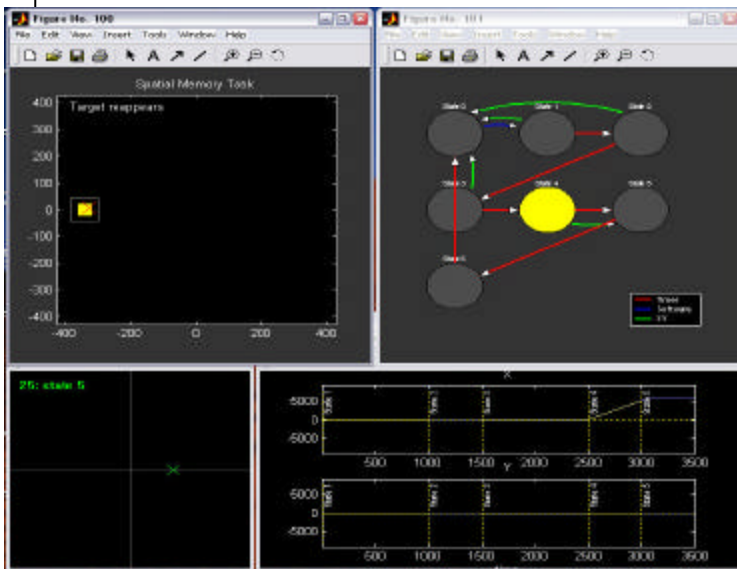

This screenshot shows sample applications (available online at www.neurocraft.com) in use with the ECM application during a spatial memory task experiment.

ECM Front Panel DB15 Connector:

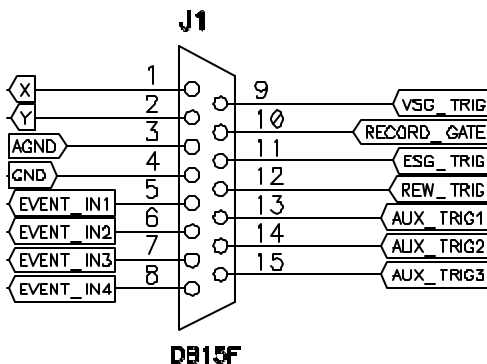

Inputs:

- X (analog, +/-0.5V or 0-1V ranges)
- Y (analog, +/-0.5V or 0-1V ranges)
- Event In 1 (TTL), for gating or daisy-chaining, level or edge sensitive
- Event In 2 (TTL), aux input, e.g. for bar press, edge sensitive
- Event In 3 (TTL), aux input, e.g. for photodiodes, level or edge sensitive
- Event In 4 (TTL), aux input, e.g. for photodiodes, edge sensitive

Outputs:

- Visual Stimulator Trigger Out (TTL)
- Trial Gate Out (TTL)
- Trial Validate Out (alias Reward Out) (TTL)
- Electrical Stimulator Trigger Out (TTL)
- Aux Trigger Out 1 (TTL)
- Aux Trigger Out 2 (TTL)
- Aux Trigger Out 3 (TTL)

ECM Experimental Control Module

System Configuration & Ordering Information

INSTRUMENTATION AND MICROELECTRODES FOR NEUROSCIENCE RESEARCH

REPRESENTATIVE SYSTEM CONFIGURATION

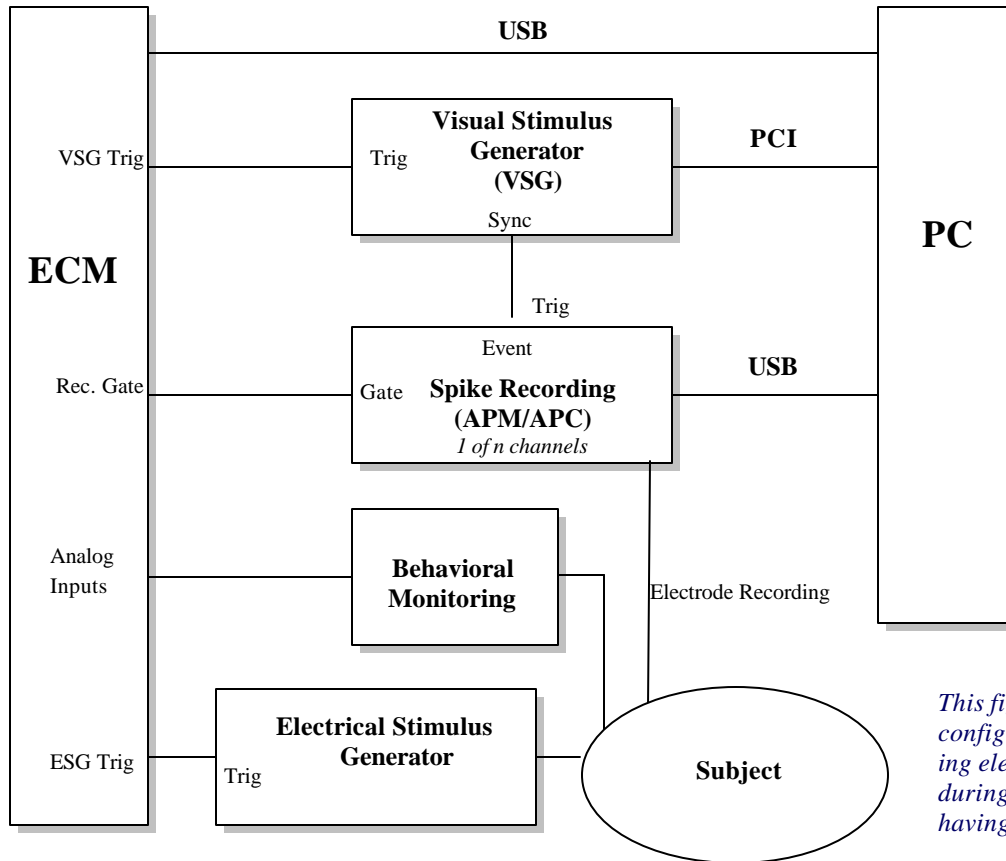

This figure shows a representative configuration of the ECM coordinating electrophysiology recordings during a vision experiments in behaving, awake animals.

Ordering Information

1 ea. Cat. #55-50-0 ECM Includes: ECM Module, Manual, Accessory Kit (Power Transfer Cord, Software Setup Kit, USB 2.0 Cable, BNC Adaptor Cables (2ea.), Rubber Feet (4 ea. Use Optional)

The following additional items are REQUIRED FOR OPERATION and must be ordered separately:

1 ea. Cat. # 55-50-1(iin) Digital I/O Adaptor Cable (specified when ordered)

1 ea. 55-00-1 12V Desktop Power Supply

1 ea. 55-XXX Line Cord as specified from chart, at right

Line cord catalog numbers, by country

55-AUS	Australia	55-JA	Japan
55-CH	China	55-SAF	South Africa
55-DAN	Denmark	55-SWI	Switzerland
55-EURO	Europe	55-UK	United Kingdom
55-ISR	Israel	55-USA	North America
55-ITA	Italy		